

Vehicle Crossover (Driveway) Application 2023/24

Purpose of Form: This form is to be used to process your request for a vehicle crossover.

Is this application for a driveway crossover required by a Development Permit for a **Material Change of Use, Reconfiguring a Lot, or Operational Works?**

YES Permit Number: There are no further application fees. Complete the application checklist below and deliver to a Council Customer Service Office or email to: development@frasercoast.qld.gov.au .

NO Application fees are payable. Complete the application checklist below and deliver to a Council Customer Service office with the application fees or email to engineering.services@frasercoast.qld.gov.au see below for payment methods.

Vehicle Crossover \$436.00

Inspection Fee (per visit) \$294.00

APPLICATION CHECKLIST

Prior to submitting your application, please ensure the mandatory items listed below are supplied. If these items are **not** supplied your application will automatically be assessed as not meeting criteria and you will receive correspondence advising your application is 'not approved'.

Completed applicant information including proposal of works and permission obtained from property owners (**all fields are mandatory**)

Provided or sketched a detailed site plan for vehicle crossover location (Page 3) including clear distances and measurements from property boundary lines and relevant land markings, and show any existing crossovers (**mandatory**)

I have read and understand the 'Responsibilities on Road Reserve.'

I have read and understand the Vehicle Crossover specifications including standard drawings.

PREFERRED RESPONSE METHOD: Mail Email

OFFICE USE ONLY

Date:	Receipt no:	Amount Paid: \$
CSO:		DOCS Reference #:
Application Checklist Completed Above: <input type="checkbox"/>		Detailed site plan attached including measurements: <input type="checkbox"/>

Methods of Payment

In Person	By Phone	By Mail
At any Council Office Cash, cheque, EFTPOS or credit card is accepted at our Customer Service Centres between 8.15am - 4.30pm Monday – Friday	Contact a Customer Service Centre on 1300 79 49 29 for credit card payment on complete applications which have already been lodged between 8.15am - 4.30pm Monday – Friday	Post completed form with cheque/money order only to:- Chief Executive Officer Fraser Coast Regional Council PO Box 1943 HERVEY BAY QLD 4655

APPLICANT INFORMATION AND PROPOSED WORKS

Principal contractor business name:			
Principal contractor contact representative:			
Postal Address:			
Phone:		Fax:	
Email:			
Proposed work to be undertaken:			
Property (Location of Work) address:			
Has property owner's permission been obtained?	<input type="checkbox"/> YES <input type="checkbox"/> NO <i>Property owners name:</i>		
Is this a second driveway?	<input type="checkbox"/> YES <input type="checkbox"/> NO		
Indicate type of kerb and channeling in front of property:	<i>Type of vehicle crossover</i> <input type="checkbox"/> Residential invert plain concrete/asphalt/compacted road base <input type="checkbox"/> Rural pipe plain concrete invert/asphalt invert/compacted road base <input type="checkbox"/> Commercial plain concrete invert/asphalt invert/compacted road base		
Proposed commencement date:	____/____/____		
Proposed completion date:	____/____/____		
<p>Detailed site plan for crossover location required to process this form.</p> <p>Please use the area supplied or provide building site plan with crossover included.</p> <p>Please note that Council will only commence action required upon receipt of full payment.</p>			

MANDATORY: Detailed site plan for vehicle crossover location including distances and measurements from property boundary and relevant landmarks:

Responsibilities on Road Reserve

Advice (WHSQ & Council & Dept. Main Roads Requirements)

This summary of Workplace Health and Safety, Council and Main Roads requirements has been provided for your assistance in establishing your own responsibilities for works in reserves. As a Principal Contractor or relevant person, it is **your** responsibility to ensure compliance with all legislation and permits prior to undertaking any works, such as vehicle crossover construction, site access, pipe laying, footpath construction or any other works relevant to public reserves.

WHSQ (for Principal Contractors and Relevant Persons)

- WHSQ Regulation requires all work to be carried out according to the WHSQ Traffic Management for the Construction or Maintenance Work Code of Practice 2008.
- A Work Method Statement is also required from the relevant person to provide information for controlling risks that exist in the work carried out on or near the roadway.
- When the work on the road reserve coincides with traffic or pedestrians' movements, reference to the *Austrroads Guide to Temporary Traffic Management (AGTTM)* is required. This manual covers the use and placement of signage and the possible need for Traffic Controllers.
- A Traffic Management Plan required by the Legal Authority, Dept. Main Roads, or the Local Authority (Fraser Coast Regional Council, to alter conditions on the roadway, can be used as part of the above Safety Plan and Work Method Statement.
- These documents are to be available on the site where works are taking place, together with additional requirements, such as: Site Specific Induction recordings.
- Site Specific Inductions are to cover and record, general safety information, sighting of Blue Cards and Prescribed Occupation Certificate details, for all workers engaged to work on the site.
- Inspectors appointed under WHSQ enforce the above requirements by conducting assessments and issuing their enforcement notices.

Fraser Coast Regional Council & Dept. Main Roads

(For Persons in Control, Principals and Contractors)

- Main Roads need a Form M994 completed and forwarded to the District Director for works for approval, where contracts are entered into.
- Fraser Coast Regional Council requires an application for a permit to work on their roads and reserves. This application must detail the type of work proposed to be undertaken, the method of operation and Traffic Management Plan. **No works are to commence** on Council owned land/reserves until a permit from Fraser Coast Regional Council has been issued. Thereafter there is a minimum of seven days notification to emergency services is required for partial or full road closures. Permits are issued through the External Services Directorate.
- Similar to Main Roads, Fraser Coast Regional Council requires a Traffic Management Plan that lays out the placement and types of signage to be erected and be submitted for approval in accordance with the *Austrroads Guide to Temporary Traffic Management (AGTTM)*.
- Both Fraser Coast Regional Council and Main Roads need a record of signage layout, kept daily by site personnel. This is a legal requirement for proceedings resulting from an accident.
- Authorized officers from the Police Service, Fraser Coast Regional Council, Main Roads, Workplace Health and Safety and Dept. of Transport can enforce these matters where the safe and effective regulation of traffic is lacking or not complying. These officers will be using their respective enforcement tools.

These responsibilities are covered under legislations; the Transport Operations (Road Use Management) Act 1995 and the Workplace Health and Safety Act 1995.

Your understanding of the above areas of responsibility is mandatory to operate and work safely on roadways including footpaths. Please enquire of the three entities before you commence your undertaking.

Vehicle Crossover Specification

General

All works associated with vehicle crossovers must be approved by Council prior to construction commencing. All works must be undertaken by a competent Contractor using accepted trades practices and quality workmanship. Public liability cover is required.

Vehicle crossover construction shall include all the associated works including traffic control, saw cutting the kerb and footpath, excavation, compaction, and removal of surplus material.

This specification is to be read in conjunction with the standard drawings (see below).

Service alterations

All existing service covers/lids shall be incorporated flush with the vehicle crossover finished level. Should services require alteration notification shall be given to the appropriate service authority at least 14 days prior to construction. Any service alteration shall be at the property owner's expense.

Vehicle crossover Locations

There are some locations where vehicle crossovers will not normally be permitted. These are outlined in section 3 AS 2890.1 and include but are not limited to:

1. On the radius of an intersection and 6m beyond the tangent point;
2. Opposite a tee intersection;
3. Where sight distance is restricted; or
4. On major roads where traffic turning right into vehicle crossover will restrict through traffic movement.

Workplace Health and Safety

The Permittee is nominated Principal Contractor under the Workplace Health and Safety Act and is responsible for ensuring the Contractors, employed to perform works at the site have procedures in place to satisfy the requirements of the Workplace Health and Safety Act and Regulations.

The cost of any action undertaken by Council to make the construction site safe shall be recovered from the property owner as a charge against the land.

Traffic Control

Traffic control shall be in accordance with *Austroads Guide to Temporary Traffic Management (AGTTM)*. The Contractor shall complete a traffic management plan outlining how traffic control will be provided in accordance with AGTTM. This information shall be conveyed to all Contractors and their staff working on the site.

Standard Drawings

The dimensions of vehicle crossovers are shown on the following standard drawings:

1. FC-230-01 Residential Driveway Slab and Tracks
2. FC-230-02 Commercial Driveway Slab
3. FC-230-03 Rural Access Pipe/Box Culvert and Invert Crossovers

Property owners are advised that the drawings are based on the most commonly used vehicles however there will be some vehicles that require specific design considerations e.g., limousines, cars with caravans.

It is important to ensure that for kerbed streets the level after the first 1.5m of the vehicle crossover matches that of the kerb. This will reduce the risk of stormwater flowing back into properties that are beneath the road level. Also, where the vehicle crossover traverses the footpath zone, the grade of the vehicle crossover shall be set at a maximum of 2.5%.

Construction of piped crossovers need to ensure that there is a dip in the access that is lower than the road so that if the table drain overflows, water is less likely to flow onto the traffic lanes.

Subgrade

The subgrade shall be formed at the required depth below the finished surface level. All soft, yielding or otherwise unsuitable material shall be replaced with sound material. The subgrade and bedding/base material shall then be compacted with mechanical compaction equipment. Just prior to pouring concrete, the subgrade should exhibit suitable moisture content.

Materials

Vehicle crossovers may be constructed using concrete, asphalt, pavers, or gravel road base.

Concrete: Only premix concrete shall be used, the minimum strength shall be N25. Formwork shall be used on all sides and securely fixed. The concrete shall be fully compacted. Expansion joints, 10mm in width for the full depth of paving, shall be constructed at the back of the vehicle crossover ramp 1.5m from and parallel to the kerb and where the crossover abuts against the footpath. Expansion joints shall consist of a preformed jointing material of bituminous fibreboard or equivalent. In unreinforced concrete construction joints shall be cut at 3m centres both perpendicular and parallel to the road and shall be cut as soon as the concrete has cured sufficient to walk on.

Asphalt: A minimum 200mm of road base shall be provided beneath the asphalt. The minimum depth of asphalt is 25mm for a residential crossover and 40mm for an industrial crossover. An increased depth of road base may be required beneath commercial crossovers (specific design required).

Pavers: Residential crossovers shall use pavers at least 50mm thick and commercial crossovers shall use pavers at least 60mm thick. Herringbone is the recommended laying pattern. All pavers shall be confined by standard edging blocks set in concrete flush with adjacent surfaces.

A minimum 150mm of road base shall be provided beneath the pavers. An increased depth of road base may be required beneath commercial crossovers (specific design required). Design and construction guidelines for clay pavers are provided by the Clay Brick and Pavers Institute www.claybrick.com.au.

Design and construction guidelines for concrete pavers are provided by the Concrete Masonry Association of Australia www.cmaa.com.au.

Gravel Road Base: A minimum 200mm of gravel road base shall be provided. An increased depth of road base may be required beneath commercial crossovers (specific design required).

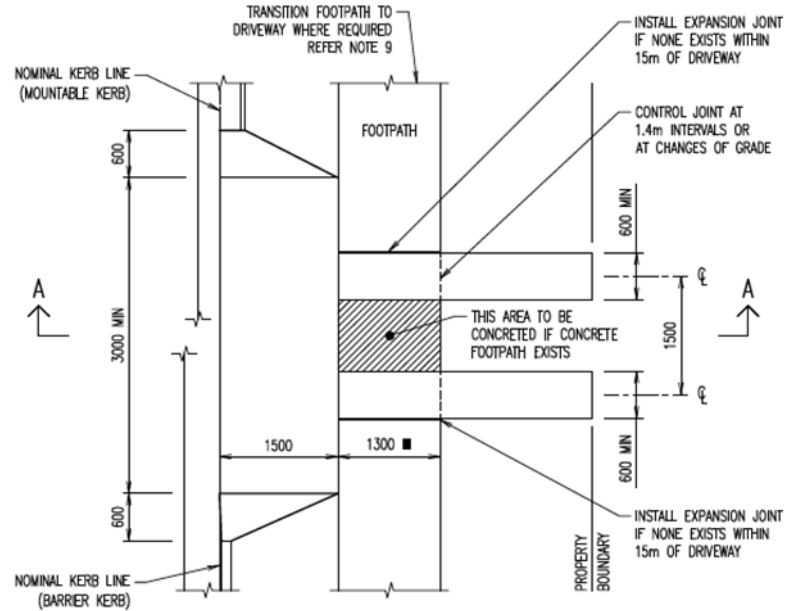
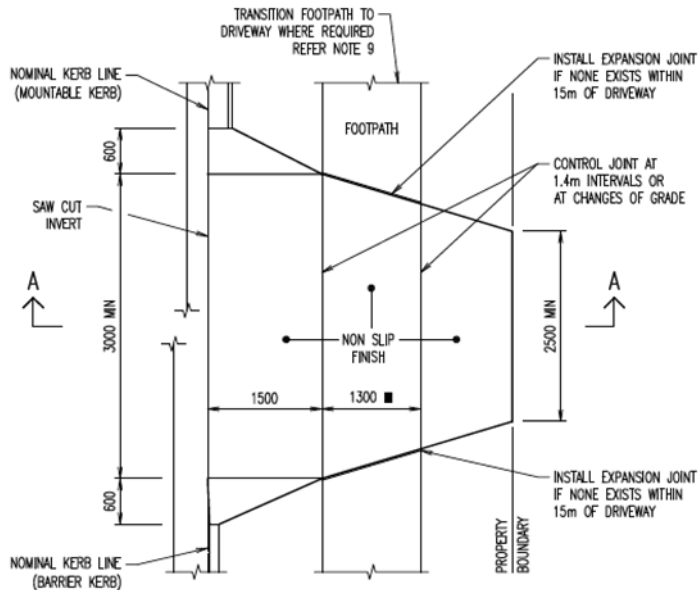

SLAB TYPE

**TRACK TYPE
(FOR EXISTING TRACK DRIVEWAYS)**

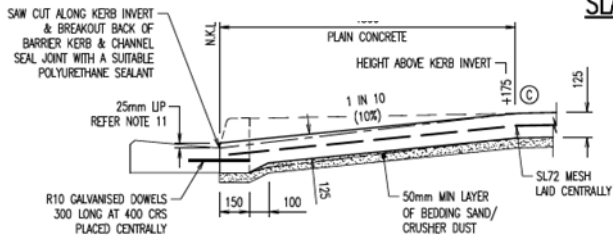

BARRIER KERB & CHANNEL - BREAKOUT

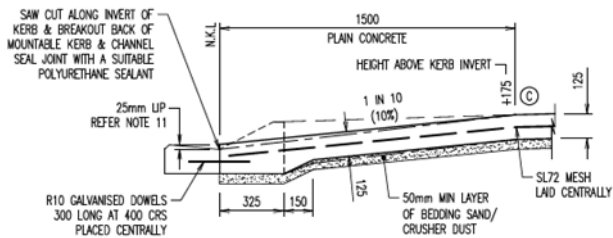

MOUNTABLE KERB & CHANNEL - BREAKOUT

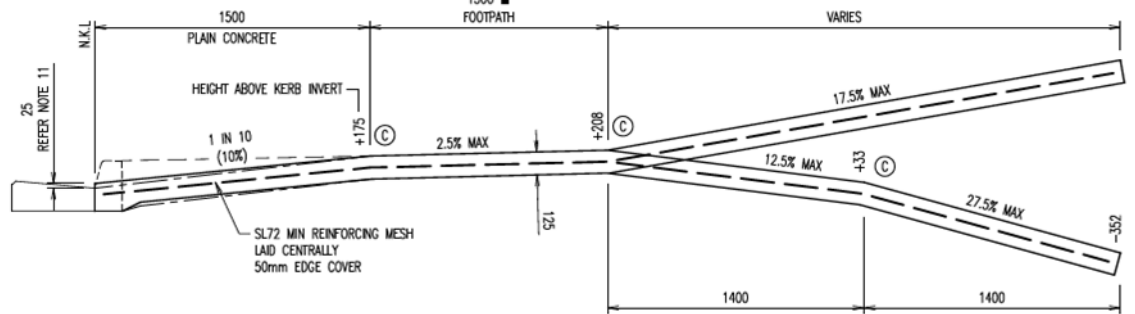

SECTION A-A

F			
E			
D			
C			
B	FOOTPATH WIDTH, NOTES ALTERED & TITLEBLOCK CHANGE		08/16
A	ORIGINAL ISSUE		01/11
REV	DETAILS OF AMENDMENTS	APPROVED	DATE



RESIDENTIAL DRIVEWAY CROSSING SLAB AND TRACKS			
DESIGN OFFICE	CHECKED CWB*	APPROVED BY DIRECTOR INFRASTRUCTURE SERVICES Davendra Naidu*	DATE 08/16
* SIGNED ORIGINAL HELD IN THE DESIGN OFFICE			

STANDARD DRAWING	
SHEET 1 OF 1	
STANDARD DRAWING No:	
A3	FC-230-01
A	B

NOTES: RESIDENTIAL DRIVEWAY CROSSING SLAB AND TRACKS

1. This crossing is not designed for commercial vehicles. For commercial vehicle/industrial crossings refer FCRC STD FC-230-02
2. Driveway configuration and dimensions are consistent with the standard road cross falls of 3%. If road cross fall exceeds 3%, driveway profile may need to be redesigned to ensure satisfactory clearance for vehicles. Driveway profile may be varied to suit difficult or existing conditions with approval by Council.
3. Approved materials for construction: Concrete, paving blocks on minimum 150mm compacted road base or asphalt on minimum 200mm compacted road base, refer project drawings.
4. Concrete to be grade N32 in accordance with AS 1379 and AS 3600.
5. Reinforcing mesh to AS/NZS 4671, laid centrally with 50 mm edge cover.
6. Concrete to be broom finished for slip resistance to AS 4586.
7. Finishes other than broom finished concrete to be approved by Council, with regards to long term slip resistance and durability. The thickness of decorative surfacing is additional to the concrete thickness shown.
8. Adjoining concrete footpaths and verge may require re-profiling to match driveway. Verge earthworks must be well compacted, top dressed and turfed. Earthworks cut and fill batters to be a maximum grade of 1 in 6.
9. Where existing footpath to be transitioned to new driveway crossing, transition footpath at a maximum grad of 1 in 14
10. Expansion joints to be full depth 10mm thick closed cell cross linked polyethylene foam (85-150kg/m³) or full depth 10mm thick compressed granulated corkboard. Seal surface of joint with a suitable polyurethane sealant.
11. 25mm lip at channel invert may be provided on both type 'A' and type 'B' kerb and channel types to prevent water flow ingress on flat or negative verge cross falls and steep longitudinal grades on kerb, where mobility access is required at driveway crossing, remove lip from driveway profile. Grade on driveway crossing not to exceed 1 in 8.
12. All appropriate permits must be obtained from Council, including approval of location and levels prior to excavation.
13. The maintenance of all accesses from the through road pavement to the property boundary is the responsibility of the property owner.
14. Maximum allowable grade change to be 15%.
15. Dimensions are in millimetres unless shown otherwise.

LEDGEND

- Footpath width, refer project drawings
- N.K.L Nominal kerb line (kerb invert)

- © Control joint

F			
E			
D			
C			
B	FOOTPATH WIDTH, NOTES ALTERED & TITLEBLOCK CHANGE		08/16
A	ORIGINAL ISSUE		01/11
REV	DETAILS OF AMENDMENTS	APPROVED	DATE



RESIDENTIAL DRIVEWAY CROSSING SLAB AND TRACKS			
DRAWN DESIGN OFFICE	CHECKED CW8 *	APPROVED BY DIRECTOR INFRASTRUCTURE SERVICES Davendra Naidu *	DATE 08/16
* SIGNED ORIGINAL HELD IN THE DESIGN OFFICE			

STANDARD DRAWING	
SHEET	1 OF 1
STANDARD DRAWING No:	
A3	FC-230-01
A	B

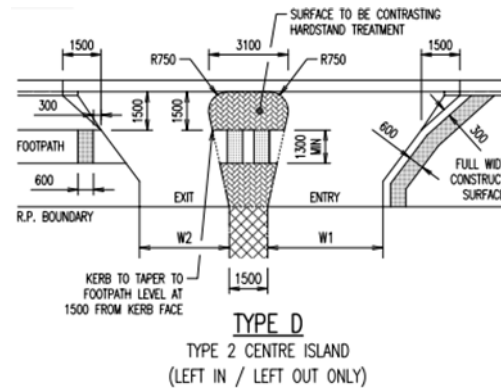
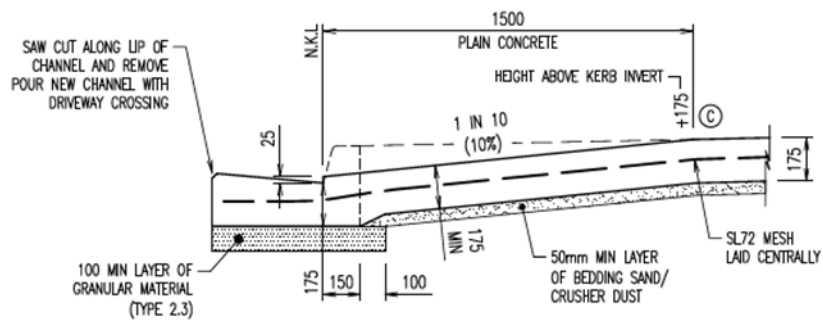
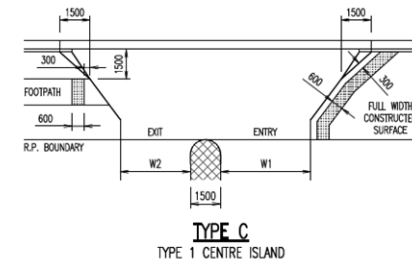
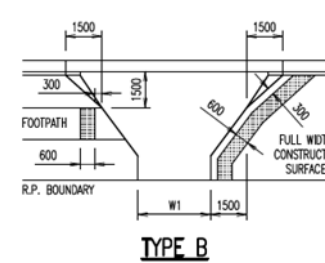
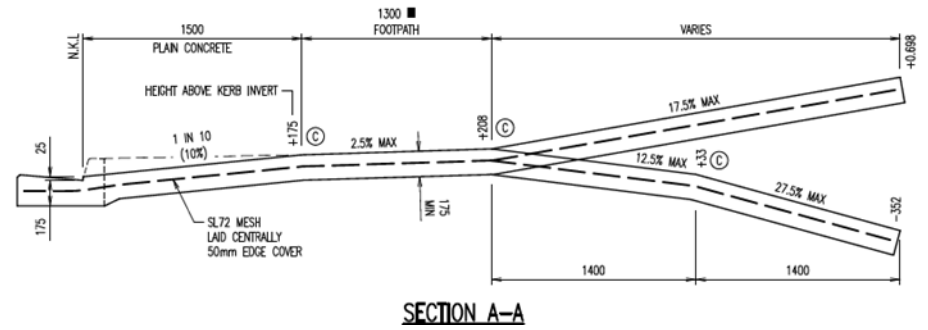
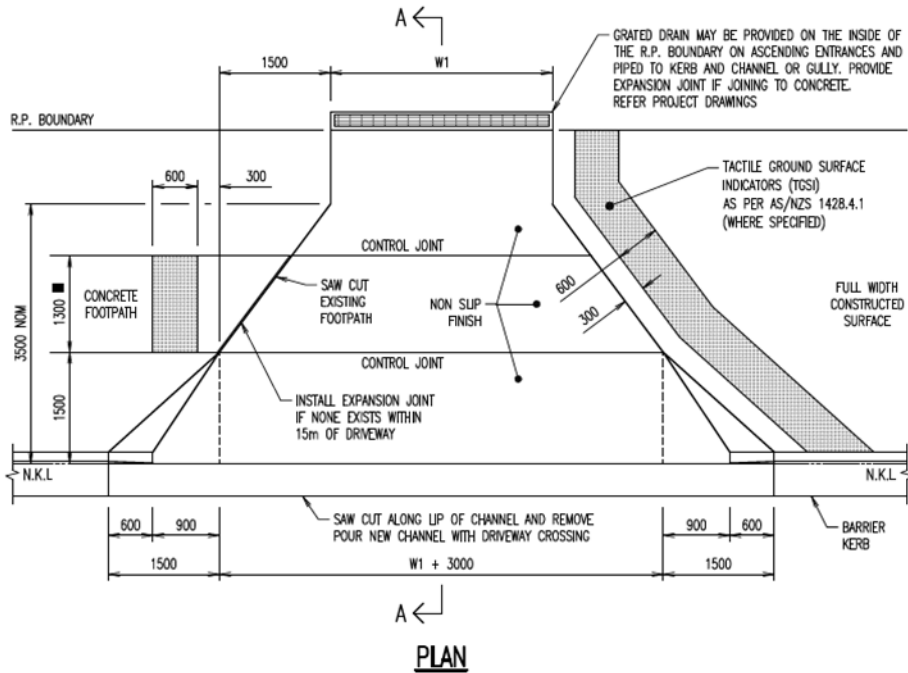

COMMERCIAL/INDUSTRIAL VEHICLE CROSSING DETAILS

TYPE	W1	W2
B	6.0 - 9.0	-
C1 / D1	4.5	3.5
C2 / D2	5.5	5.0
C3 / D3	7.5	6.0
C4 / D4	9.0	7.5

F			
E			
D			
C			
B	DRIVEWAY TYPES ADDED, FOOTPATH WIDTH, NOTES ALTERED & TILEBLOCK CHANGE		08/16
A	ORIGINAL ISSUE		01/11
REV	DETAILS OF AMENDMENTS	APPROVED	DATE



COMMERCIAL/INDUSTRIAL DRIVEWAY CROSSING HEAVY DUTY SLAB			
DESIGN OFFICE	CWB*	APPROVED BY DIRECTOR INFRASTRUCTURE SERVICES Davendra Naidu*	DATE 08/16
* SIGNED ORIGINAL HELD IN THE DESIGN OFFICE			

STANDARD DRAWING	
SHEET 1 OF 1	STANDARD DRAWING No.
A3	FC-230-02
A	B

NOTES: COMMERCIAL / INDUSTRIAL DRIVEWAY CROSSING HEAVY DUTY SLAB

1. Concrete to be grade N32/20 in accordance with AS 1379 and AS 3600.
2. Reinforcing mesh to AS/NZS 4671. Mesh to be laid centrally with 50mm edge cover, lap fabric 250mm.
3. Concrete to be broom finished for slip resistance to AS 4586.
4. Finishes other than broom finished concrete to be approved by Council. With regards, to long term slip resistance and durability. The thickness of decorative surfacing is additional to the concrete thickness specified.
5. Depths of concrete and reinforcing steel shown are the minimum requirements for good subgrade conditions and average traffic loading. Where this does not apply. Depths of concrete and reinforcing shall be increased to suit specific conditions.
6. Where the subgrade is less than CBR 5, excavate and provided imported granular material to satisfaction of council.
7. Dimension W1 & W2, refer project drawings.
8. All existing asphalt or concrete pavements to be saw cut prior to allow for neat removal and reinstatement.
9. Full cross section of kerb and channel to be removed and reinforcing mesh to extend to within 50mm of channel lip. Road pavement to be cement treated if disturbed during removal of kerb and channel and resurfaced with bitumen or asphalt to match road surface.
10. Adjoining concrete footpaths and verge may require re-profiling to match driveway, verge earthworks must be well compacted, top dressed and turfed. Earthworks cut and fill batters to be a maximum grade of 1 in 6.
11. Existing footpath profile to be maintained where possible. Variations to the design profiles shown are subject to approval by council.
12. Where directed by council tactile ground surface indicators (TGSIS) are to be provided adjacent to the driveway in accordance with AS/NZS 1428.4.1.
13. Expansion Joints to be full depth 10mm thick closed cell cross linked polyethylene foam (85-150kg/m3) or full depth 10mm thick compressed granulated corkboard. Seal surface of joint with a suitable polyurethane sealant.
14. All appropriate permits must be obtained from Council, including approval of location and levels prior to excavation.
15. The maintenance of all accesses from the through road pavement to the property boundary is the responsibility of the property owner.
16. Maximum allowable grade change to be 15%.
17. Dimensions are in millimetres unless shown otherwise.

LEDGEND

- Footpath width, refer project drawings.
- N.K.L Nominal kerb line (kerb invert)
- © Control joint

F			
E			
D			
C			
B	DRIVEWAY TYPES ADDED, FOOTPATH WIDTH, NOTES ALTERED & TILEBLOCK CHANGE		08/16
A	ORIGINAL ISSUE		01/11
REV	DETAILS OF AMENDMENTS	APPROVED	DATE



COMMERCIAL/INDUSTRIAL DRIVEWAY CROSSING HEAVY DUTY SLAB			
DRAWN	CHECKED	APPROVED BY DIRECTOR INFRASTRUCTURE SERVICES	DATE
DESIGN OFFICE	CWB *	Davendes Naidu*	08/16
* SIGNED ORIGINAL HELD IN THE DESIGN OFFICE			

STANDARD DRAWING			
SHEET	1	OF	1
A3	FC-230-02		
A	B		

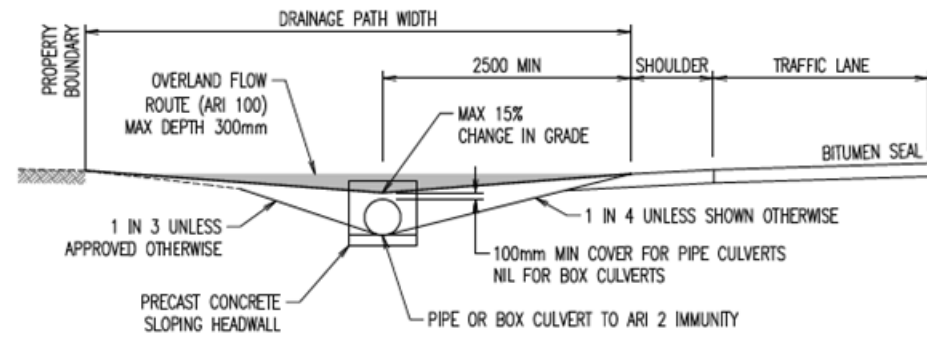
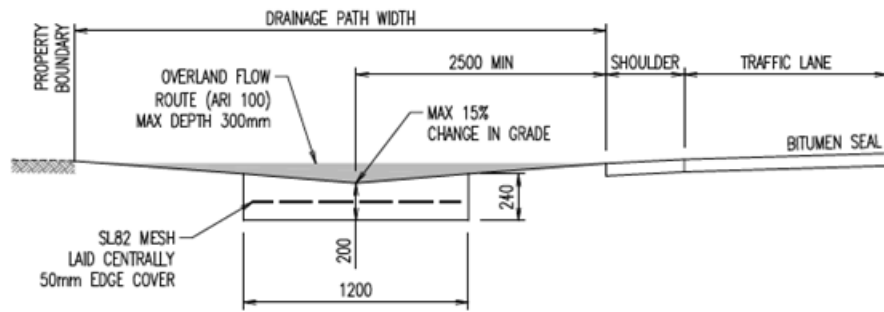
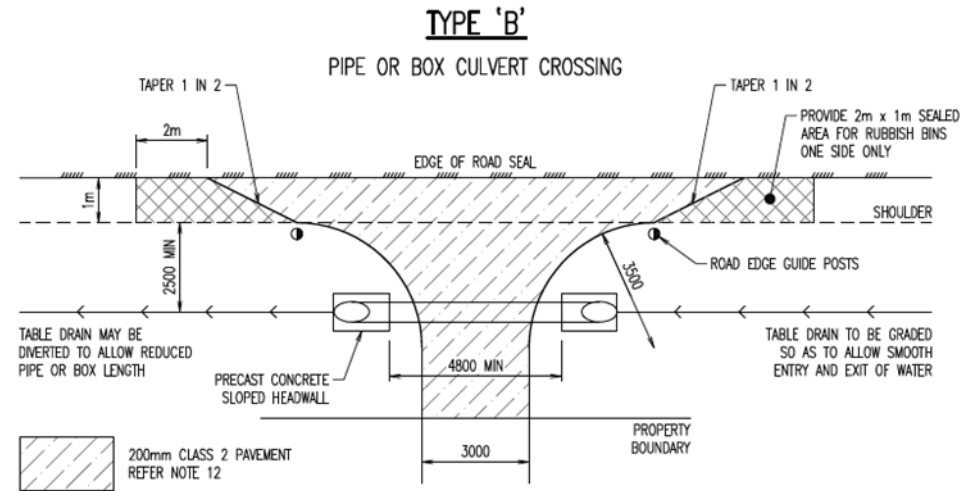
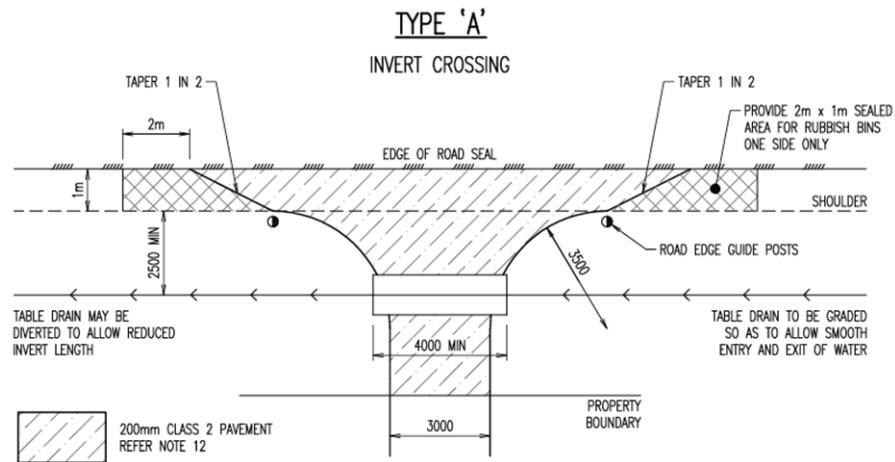

F			
E			
D			
C			
B	REGD ADDED, NOTES ALTERED & TITLEBLOCK CHANGE		08/16
A	ORIGINAL ISSUE		01/11
REV	DETAILS OF AMENDMENTS	APPROVED	DATE



RURAL ACCESS PIPE OR BOX CULVERT AND INVERT CROSSINGS			
DRAWN	CHECKED	APPROVED BY DIRECTOR INFRASTRUCTURE SERVICES	DATE
DESIGN OFFICE	CWB *	Davendra Naidu *	08/16
* SIGNED ORIGINAL HELD IN THE DESIGN OFFICE			

STANDARD DRAWING			
SHEET 1 OF 1		STANDARD DRAWING No:	
A3		FC-230-03	
A		B	

NOTES: RURAL ACCESS PIPE OR BOX CULVERT AND INVERT CROSSING

1. Pipe or box culvert crossings are not to be installed on road that fall to the subject property or where stormwater cannot be directed to a natural water course or drainage easement/system or when there is no upstream stormwater catchment or table drain.
2. Access driveways with grades greater than 10% (1in 10) within property boundaries shall be constructed with non-erodible material (i.e., bitumen, asphalt, concrete, pavers).
3. Table drains and outlets prone to scouring shall be lined with rock, concrete, or stabilised turf for protection.
4. All drainage from within the property and on the driveway, surfaces shall be collected at or inside the property boundary and discharged by way of a sealed pipe or other approved means to Council’s drainage system.
5. The access shall be positioned so as the approach sight distance meets the criteria as stipulated in section 5 of Austroads publication “Intersections at Grade”. Earthworks required within the road reserve to achieve the criteria shall be approved by Council.
6. Calculations for the sizing of pipe or box culverts shall be carried out by a registered professional engineer and approved by Council. Pipe or box culvert design shall provide a minimum ARI 2 immunity.
7. Minimum pipe diameter to be 300mm and minimum box height to be 225mm unless otherwise approved by Council.
8. Where pipe is used for a rural access, pipe to be a minimum class reinforced concrete pipe (fibre or steel reinforced).
9. Minimum pipe or box grade to be 0.5%
10. Low point of access to be a min of 100mm below shoulder hinge point.
11. All Culvert, invert and driveway construction shall be carried out in the section of road reserve contained within the extended property boundary lines.
12. Where an access crossing is required to be provided as a condition of a development permit, a 200mm gravel pavement with a 2-coat bitumen seal shall be provided. Council fee for the installation of a crossing does not include pavement or bitumen surfacing work.
13. Rural access culvert length min 4.8m, max 7.0m between headwalls should a culvert longer than 7.0m be required the owner/developer shall seek written approval from council for the proposal and have the water flow capacity sized in accordance with the development manual.
14. Where access cannot be constructed in accordance with this standard, a sketch of proposal shall be submitted to council for approval.
15. All underground services are to be located on site prior to any excavations works.
16. All appropriate permits must be obtained from Council, including approval of location and levels prior to excavation.
17. The maintenance of all accesses from the through road pavement to the property boundary is the responsibility of the property owner.
18. Maximum allowable grade change to be 15%.
19. Dimension are in millimetres unless shown otherwise.

F			
E			
D			
C			
B	REG. ADDED, NOTES ALTERED & TITLEBLOCK CHANGE		08/16
A	ORIGINAL ISSUE		01/11
REV	DETAILS OF AMENDMENTS	APPROVED	DATE



RURAL ACCESS PIPE OR BOX CULVERT AND INVERT CROSSINGS			
DRAWN	CHECKED	APPROVED BY DIRECTOR INFRASTRUCTURE SERVICES	DATE
DESIGN OFFICE	CWB*	Davendra Naidu*	08/16
* SIGNED ORIGINAL HELD IN THE DESIGN OFFICE			

STANDARD DRAWING			
SHEET		1 OF 1	
STANDARD DRAWING No:			
A3		FC-230-03	
K	B		

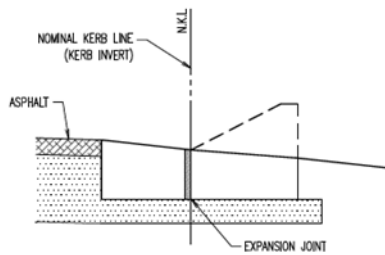

SECTION A-A
FOR TYPE 'B' MOUNTABLE KERB

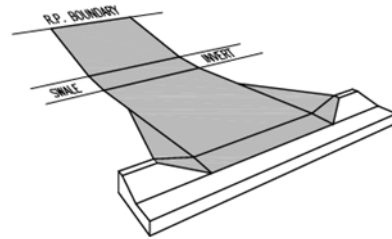

PERSPECTIVE VIEW

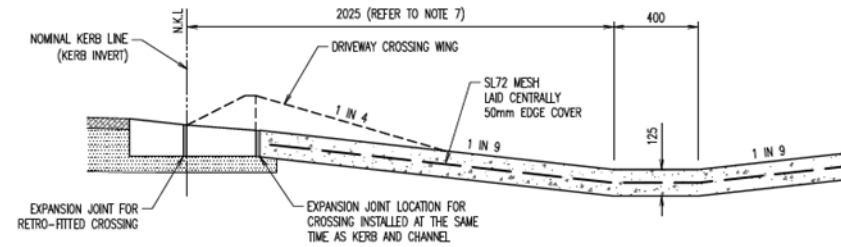

SECTION
(WITH TYPE 'B' MOUNTABLE KERB)

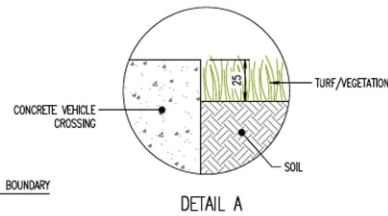

DETAIL A

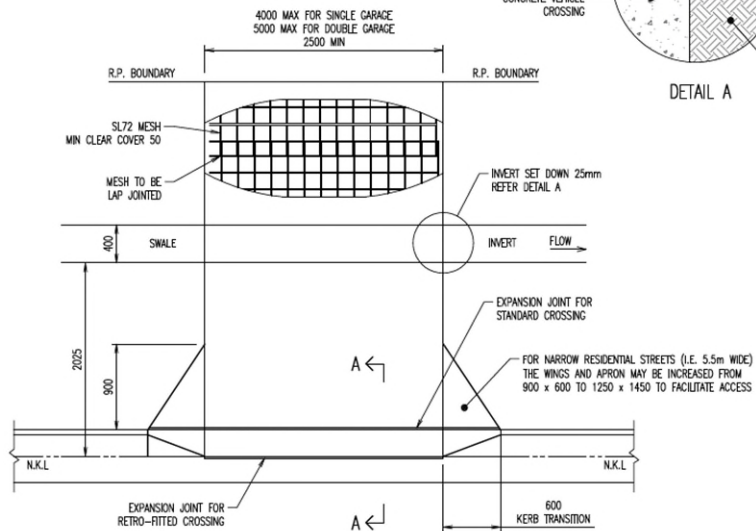

PLAN

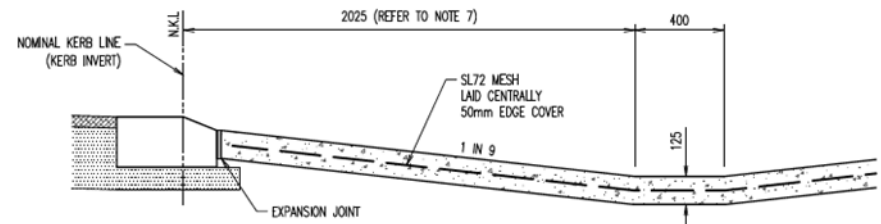

SECTION
(WITH TYPE 'M' MOUNTABLE KERB)

F			
E			
D			
C			
B	NOTES ALTERED & TITLEBLOCK CHANGE		08/16
A	ORIGINAL ISSUE		01/11
REV	DETAILS OF AMENDMENTS	APPROVED	DATE



RESIDENTIAL VEHICLE CROSSING SWALE PROFILE			
DRAWN DESIGN OFFICE	CHECKED CWB *	APPROVED BY DIRECTOR INFRASTRUCTURE SERVICES Davenendra Naidu*	DATE 08/16

STANDARD DRAWING	
SHEET 1 OF 1	
STANDARD DRAWING No:	
A3	FC-230-04
A	B

NOTES: RESIDENTIAL VEHICLE CROSSING SWALE PROFILE

1. This crossing is not designed for commercial vehicles.
2. Concrete to be grade N32 in accordance with AS 1379 and AS 3600.
3. Reinforcing mesh to AS/NZS 4671, laid centrally with 50mm edge cover, lap fabric 250mm.
4. Concrete to be broom finished for slip resistance to AS 4586. Finishes other than broom finished concrete to be approved by Council with regards to long term slip resistance and durability.
5. The thickness of decorative surfacing where approved is additional to the concrete thickness specified.
6. Expansion joints to be full depth 10mm thick closed cell cross linked polyethylene foam (85-150 kg/m³) or full depth 10mm thick compressed granulated corkboard. Seal surface joint with a suitable polyurethane sealant.
7. Distance from nominal face of kerb may vary with swale width. Grades re recommended maximums for vehicle access.
8. Dimension are in millimetres unless shown otherwise.

LEGEND

N.K.L Nominal kerb line (kerb invert)